

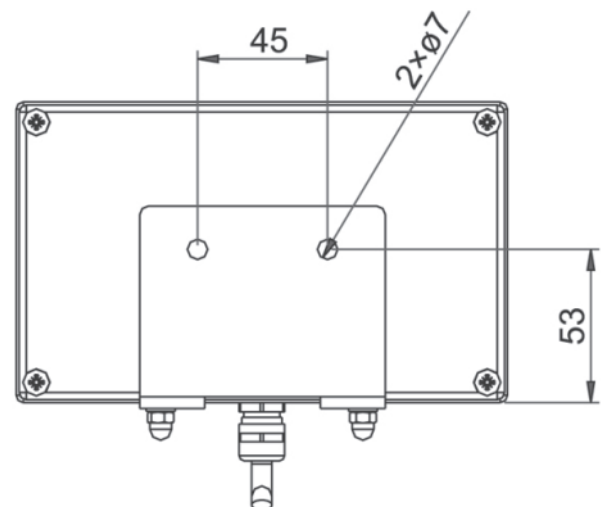

WD-4/3 : stainless steel casing, cable with 4pin input (IP67) for cooperation with measuring indicator series PUE C/31H, PUE C/31H/Z

Basic features:

- automatic detection of speed of transmission
- automatic switch off
- LCD backlight
- power supply from measuring indicator (scale)

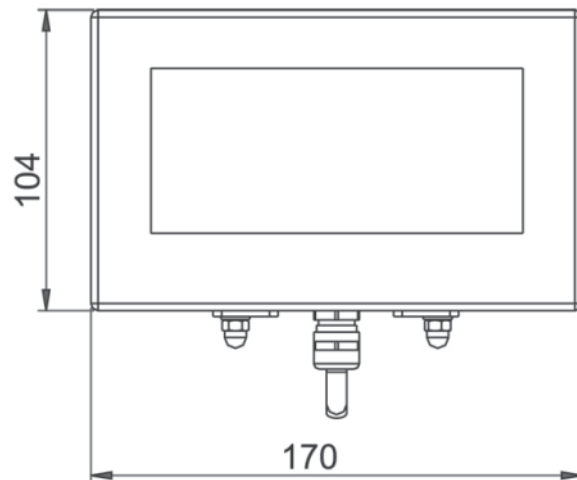
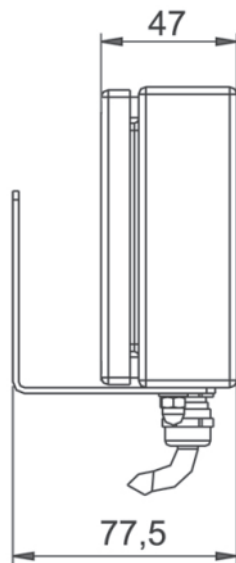

Specification:

Power supply	6V DC from measuring indicator
Digit size	19 mm
Connection cable length	1,5 m
Dimensions	170 × 104 × 47 *

* dimensions do not include cable chokes and holders for mounting